

Nishiki Amplifier in combinatie met Aikido / TubeCad circuit board.

NOTICE: this document is prepared by Wim de Haan [NL] and does not reflect any measurements by John Broskie of TubeCad. The original Aikido circuit is owned and copyrighted by John Broskie of TubeCad. All measurements are done using an experimental set-up, so final should be better than figures shown.

V3	5965					V4	5965				
config	Rk	U _{RK}	I mA	B ⁺	R15	R16	Gain in dB	vervorming bij 1 watt 1.4 Veff	Vervorming bij 45 watt 15 Veff	Vervorming bij ... watt Veff	Vervorming bij 90 watt 21 Veff
Tube-Cad	220	2.04	9.3	+300V	92K	100K		0.24	1.8		2.5
wim 1	680	2.7	4	+300			24	0.22	0.6	16.5 Veff* 0.9	-
	680	3.8	3.8	+400				0.22	0.6	-	0.82
	680	4.0	5.9	+450				0.22	0.62	-	0.72
wim 2	820	2.7	3.3	+300				0.2	0.85	18 Veff* 0.95	-
	820	3.58	4.3	+400				0.2	0.8	-	0.9
	820	3.9	4.8	+450				0.2	0.7	-	0.85

*= signal clips [circuit not recommended]

Nishiki Power Stage PSU at 1 watt output power: +/- 38V DC - PSU at full power: +/-35.5V DC - Load: 5 ohm

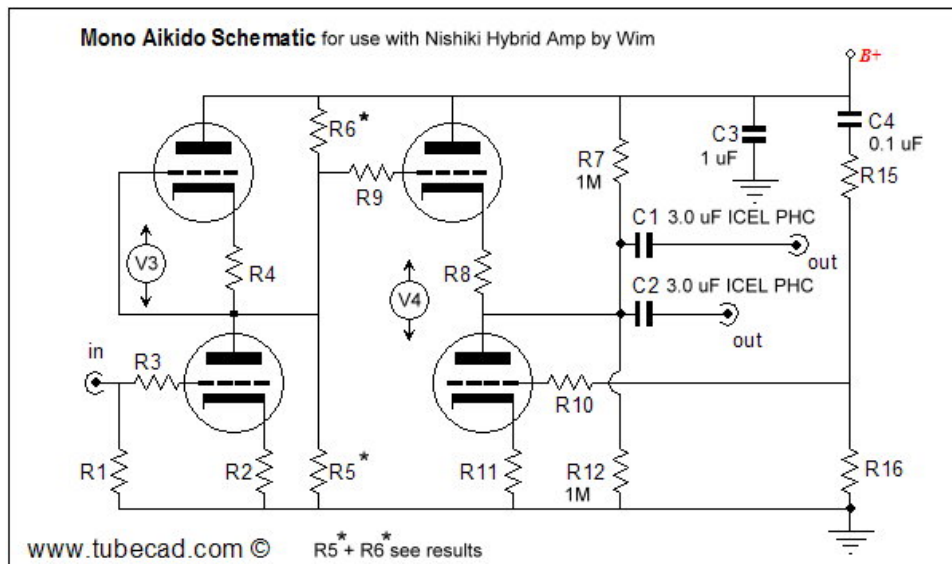

Nishiki Amplifier in combinatie met Aikido / TubeCad circuit board.

V3	ECC83 Rk= 2K					V4	ECC82 Rk= 470 ohm				
config	Rk	U _{RK}	I mA	B+	R15	R16	Gain in dB	vervorming bij 1 watt 1.4 Veff	Vervorming bij 45 watt 15 Veff	Vervorming bij ... watt Veff	Vervorming bij 90 watt 21 Veff
Tube-Cad	ECC83 ECC82	1.2 3.2	0.6 6.8	+300V	82K	100K	29	0.22	0.7	-	0.82
	ECC83 ECC82	1.7 4.6	0.85 9.8	+400				0.22	0.6	-	0.78

Nishiki Amplifier in combinatie met Aikido / TubeCad circuit board.

V3	ECC83 Rk= 2K					V4	ECC82 Rk= 1K				
config	Rk	U _{RK}	I mA	B+	R15	R16	Gain in dB	vervorming bij 1 watt 1.4 Veff	Vervorming bij 45 watt 15 Veff	Vervorming bij ... watt Veff	Vervorming bij 90 watt 21 Veff
Tube-Cad	ECC83 ECC82	- 5.2	- 5.2	+300V	100K	121K		0.22	0.48	16.5Veff* 1.1	-
	ECC83 ECC82	1.5 6.17	0.75 6.17	+350				0.22	0.25	19.0Veff* 0.82	-
	ECC83 ECC82	1.7 7.15	0.85 7.15	+400				0.22	0.22	-	0.75

*= signal clips [circuit not recommended]

V3	ECC83	Rk= 2K				V4	ECC82	Rk= 1K	
Circuit 1	Rk	U _{RK}	I mA	B+	R15	R16	Gain in dB		
	ECC83 ECC82	1.67 4.67	0.84 4.67	+400V	100K	121K	30		
distortion at 1 watt 2.3 Veff	distortion at 5 watt 5 Veff	distortion at 10 watt 7.1 Veff	distortion at 25 watt 11.2 Veff	distortion at 45 watt 15 Veff	distortion at 65 watt 18 Veff	distortion at 90 watt 21.2 Veff	distortion at max. power		
0.22	0.22	0.25	0.34	0.4	0.44	0.48	23 Veff 105 watt 0.76 %		Notice: R5+R6= 10M

V3	ECC83	Rk= 2K				V4	ECC82	Rk= 1K1	
Circuit 2	Rk	U _{RK}	I mA	B+	R15	R16	Gain in dB		
	ECC83 ECC82	1.68 6.5	1.53 5.9	+400V	100K	121K	28.5		
distortion at 1 watt 2.3 Veff	distortion at 5 watt 5 Veff	distortion at 10 watt 7.1 Veff	distortion at 25 watt 11.2 Veff	distortion at 45 watt 15 Veff	distortion at 65 watt 18 Veff	distortion at 90 watt 21.2 Veff	distortion at max. power		
0.24	0.24	0.28	0.4	0.45	0.48	0.6	23 Veff 105 watt 1.18 %		Notice: R5+R6= 1M

V3	ECC83	Rk= 2K				V4	ECC82	Rk= 1K1	
Circuit 3	Rk	U _{RK}	I mA	B+	R15	R16	Gain in dB		
	ECC83 ECC82	1.69 6.5	0.77 5.9	+400V	100K	121K	30		
distortion at 1 watt 2.3 Veff	distortion at 5 watt 5 Veff	distortion at 10 watt 7.1 Veff	distortion at 25 watt 11.2 Veff	distortion at 45 watt 15 Veff	distortion at 65 watt 18 Veff	distortion at 90 watt 21.2 Veff	distortion at max. power		
0.24	0.18	0.18	0.2	0.2	0.2	0.38	22,8 Veff 104 watt 0.95 %		Notice: R5+R6= 10M

Nishiki Power Stage PSU DC voltage no load: +/- 38.4 VDC

Nishiki Power Stage PSU DC at full load: +/- 36.1 VDC

Load: 5 ohm

Current at max. power: 2.1 ampere DC

Final configuration with extra care for test set-up regarding wiring / hum

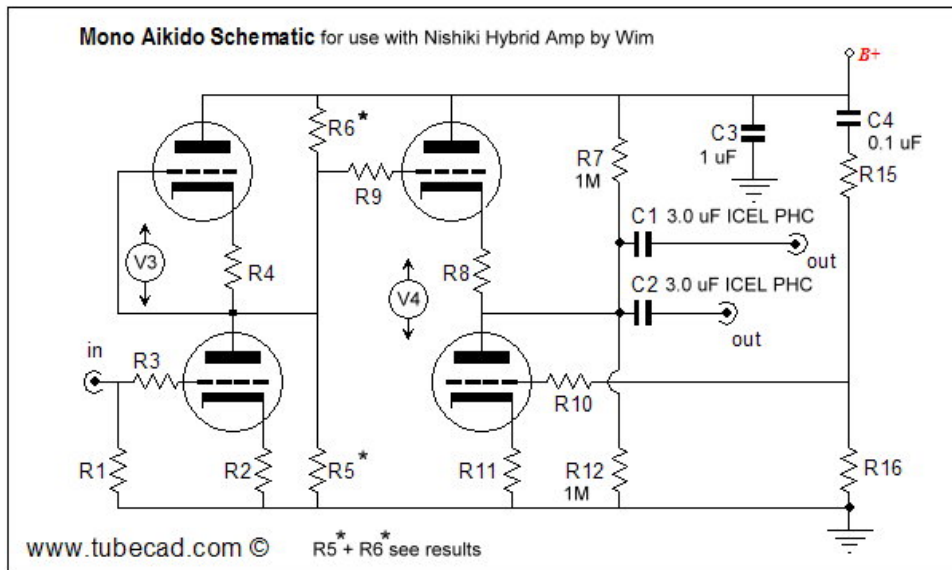

V3 + V2	ECC83		Rk = R2 + R4 = 2K			V4 + V1	ECC82		Rk = R8 + R11 = 1K1	
Circuit 4	Rk	U _{RK}	I mA	B+	R15	R16	Gain in dB			
	ECC83	1.69	0.77	+400V	100K	121K	30			
	ECC82	6.5	5.9							
distortion at 1 watt 2.3 Veff	distortion at 5 watt 5 Veff	distortion at 10 watt 7.1 Veff	distortion at 25 watt 11.2 Veff	distortion at 45 watt 15 Veff	distortion at 65 watt 18 Veff	distortion at 90 watt 21.2 Veff	distortion at max. power			
0.22	0.12	0.09	0.1	0.09	0.13	0.4	23 Veff 105 watt 1.2 %			Notice: R5+R6= 10M

V3 + V2	ECC83		Rk = R2 + R4 = 2K			V4 + V1	ECC82		Rk = R8 + R11 = 1K21	
Circuit 5	Rk	U _{RK}	I mA	B+	R15	R16	Gain in dB			
	ECC83	1.66	0.83	+400V	100K	121K				
	ECC82	6.61	5.46							
distortion at 1 watt 2.3 Veff	distortion at 5 watt 5 Veff	distortion at 10 watt 7.1 Veff	distortion at 25 watt 11.2 Veff	distortion at 45 watt 15 Veff	distortion at 65 watt 18 Veff	distortion at 90 watt 21.2 Veff	distortion at max. power			
0.22	0.1	0.08	0.08	0.08	0.14	0.5	22 Veff 96 watt 0.92 %			Notice: R5+R6= 10M